

# Smart Electric Grid Line Controller

**SAROMINES, MARK JOSEFF**  
Dr. Aurelio Mendoza Memorial Colleges  
smarkjoseff@gmail.com

**GALLEMIT, ANDREW**  
Jose Rizal Memorial State University

*Abstract* — This research presents the design, development, and validation of a Smart Electric Grid Line Controller aimed to address challenges on energy losses in the vicinity due to uncompensated electric consumption and energy theft from far flung areas which leads to unconventional power distribution. The study begins with an intensive situational analysis to identify and validate the specific issues in the relevant areas.

Based on this analysis, a device is designed, developed, and tested by experts, with the device being installed and connected to the electric meters. The evaluation of the device's effectiveness and performance is conducted through comprehensive testing, which incorporates the use of both researcher-made and standardized questionnaires. This evaluation process allows for a thorough assessment of the device's capabilities and performance in real-world scenarios.

The results of the evaluation serve as a basis for further refinement and advancement of the technology. By implementing the Smart Electric Grid Line Controller, stakeholders in any vicinity can achieve improved efficiency, reliability, and sustainability in their power distribution system.

*Keywords* — *Smart Grid, Arduino, Microcontroller*

---

## I. Introduction

Electrical energy is the most common source of energy used in every household according to the Philippine Statistics Office (PSA). The result of the 2011 Household Energy Consumption Survey (HECS), there are about 87% of 21.0 million households that depends on electricity mostly used for lighting purposes, recreation and space cooling, ironing clothes, TV viewing, VCR/karaoke/videoke, laundry, cooking and food preparation, computer activity, water heating and water pumping.

It can also be noted that while the enumerated use of electricity was distributed and utilized for residential sectors, commercial (banks, convenience store and super markets), industrial (businesses dealing with manufacturing goods such as printing and publishing, factories and industries) and other sectors (public buildings, streetlights, irrigation and energy recovered) contribute to the energy consumption.

Between the years 2017 and 2018, the most rapid growth of electric consumption came from residential consumers. It is considered as the largest consumers at 26,782,033 to 28,260,764 megawatts/hour (MWh) which shows the increase of number of consumers and household on the

said years. The rapid growth of electric consumption from years 2017 to 2018 requires rapid demand on electricity which resulted to the recent power outages and interruptions. These were followed by rotational blackout which lasted from four (4) to eight (8) hours due to insufficient power supply.

Accordingly, Region 9 is currently experiencing electricity crisis which yields to rotational black outs and power outage in the area evidently in Zamboanga Sibugay. Many cases recorded in Zamsureco II within Zamboanga Sibugay on this prevalent energy theft which unfortunately the current obstacle in this province. There are many electric energy theft incidents, specifically in the critical areas of vicinity in the Municipality of Ipil. Interventions and protocols cannot be implemented properly because it is risky and dangerous for some line men. Accordingly, this alarming situation is happening in the far-flung barangays of Ipil that enables line men to disregard connecting and disconnecting electric lines within the parameters due to its risky environment. Conventionally, the line personnel are obliged to disconnect the electric lines of the consumers who have not settled their accounts after the due date and reconnect the line after the consumers already paid their unsettled bills. Unfortunately, there are cases where personnel were threatened and harmed for disconnecting the electric lines and implementing proper protocols in the household. The strong resistance of consumer from the implementation of the disconnection is due to the fear that they cannot acquire immediate reconnection whenever needed after they have settled their accounts.

Accordingly, the stakeholder already prepared and acquired energy supply for their whole coverage of the households and consumers. Thus, there will be losses in their end if there will be no compensation from the acquired electricity in the household. The disconnection of electric lines will be the stakeholder's way to obliged the consumers of paying their acquired electricity usage since it is a basic necessity. Thus, failure to implement disconnection will initiate losses from the acquired energy supply by the stakeholders.

There are a lot of interventions taken by the government and stakeholder to address this problem of energy overcompensations and there are few evidences addressing the problem in the area regarding proper implementation of the disconnection and reconnection of electric lines which accordingly a factor reinforcing electricity crisis in the area. Thus, to the author's knowledge there's a need to develop a Smart Electric Grid Line Controller to address the need of both consumers and stakeholders on electric consumption issues.

## **Literature Review**

There is a pervasive usage of smart devices in relation to electric lines and grid nowadays. In connection to these advent technologies, this study developed a device for a convenient, faster and accurate disconnection and reconnection of electric lines to lessen energy theft and income losses of the energy distributor. This device lessen pilferage in billing by execution of

disconnection that will oblige consumers to compensate electricity usage and also serve for the advantage of the consumers in their immediate need for reconnection after their paid accounts.

The research is grounded from the concept of Smart Grid theory found in the inner core of the circle which focuses on the upgraded electricity network that integrate intelligent actions to its connectivity for sustainable and secure electricity supply. As this research objectifies the same goal, it needs more background on smart grid which were already implemented on other progressing countries, as to build further foundation necessary for the development of this device applying to the locality.

The Smart Grid represents an unprecedented opportunity to move the energy industry into a new era of reliability, availability, and efficiency that will contribute to our economic and environmental health. During the transition period, it will be critical to carry out testing, technology improvements, consumer education, development of standards and regulations, and information sharing between projects to ensure that the benefits we envision from the Smart Grid become a reality. Potential benefits of the Smart Grid are usually discussed in terms of economics, national security, and renewable energy goals (Smartgrid, 2015). It offers technical solutions that address the problems such as inconvenience, monitoring electricity consumption and electricity theft. Smart grid technologies are being applied across power systems, including generation, transmission, distribution, and services and consumption. Hence, with the successful and widespread development of smart grids, countries can expect high-quality electric power service, better system reliability, and quality of service (Smart Grid Task Force, 2016). Some automation has been implemented on electric metering system abroad as well as some part of the locality. For instance, automatic meter reading system is introduced in India. The aim has been to develop a cost efficient, with higher performance, rate and coverage area that is most appropriate to their system (Tanvir Ahmed, Md Suzan Miah, Md. Manirul Islam and Md. Rakib Uddin, 2014). In some, commercial smart metering products use the internet for data transmission. Stanescu et al (2016) present a design and implementation of SMS based control for monitoring systems in electricity. The usage of this prototype will minimize if not eliminate the inconvenience due to manual process in metering system.

With these smart developments, it is also essential to use microcontrollers in the devices developed to perform automation in monitoring system. Microcontrollers are essential components in many electronic devices and embedded systems. They are small, self-contained computers on a single integrated circuit (IC) that contain a processor core, memory, and various input/output peripherals. These microcontrollers are designed to perform specific tasks and are commonly used in applications like home appliances, automotive systems, consumer electronics, industrial automation, and more.

There are several types of microcontrollers as of in September 2021 namely, *Arduino Boards*: Arduino boards use various microcontrollers, with the most common being based on the Atmel/Microchip AVR family. This research used Arduino device to control the disconnection

and reconnection of electric lines. Arduino device is an electronic prototyping platform based on flexible easy to use hardware and software (Suman, 2014). According to the study of David N., Chima A., Ugochukwu A., Obinna E., (2015) It is used as a controlling and monitoring system for any access outside the parameters. This system is cost-effective at the same time it is also flexible to use. This was implemented to control and monitor the appliances at home when the owner is not around and this time, the researchers used Arduino to control and monitor stuff in their personal parameters. The web page will display all the variables being read from the Arduino micro-controller and also be able to perform the functions as the mobile application. The Wi-Fi shield connected with the Arduino board will be the link between the web pages and the Arduino. When connected to the IP address of the Arduino, the PHP and the Ajax http request will be able to send information over this IP address which in turn is interpreted by the Arduino.

There are researches that used Arduino, one of these is the study of VaniyaRohit P. Kumarkhaniya Vishal S. Solanki Sanjay C. ParmarRavirajsinh H (2019). This work is based on Arduino, motor driver and Bluetooth module. Arduino is an open-source prototyping platform based on easy-to-use hardware and software. This is a very simple and easy type form of remote-control car, where the ordinary micro-controller has been replaced by Arduino and IR sensors has been replaced by a Bluetooth module. The remote can be any android or IOS cell phones. This project can be made in a bigger scale for real time vehicles. Thus, this shows that microcontroller can be effectively used in controlling and monitoring system for any access outside the parameters.

With the necessary technology and research, it is necessary to have an initial model to administer the project before implementing it in the large scale. The Prototyping Model is a system development method (SDM) in which a prototype (an early draft of a final system or product) is built, tested and then reworked as necessary until an acceptable prototype is eventually achieved from which the complete system or product can be developed. A prototype serves as a throwaway model made to understand the requirements of a project before design and coding begins. In essence, prototyping is a project test run (Rapids Reproductions, 2018)

There are many theoretical perspectives have been developed in order to understand how end users make decisions to use technology applications. Theories provide tools to understand success or failure in implementation processes of new IT applications. Technology validation is necessary for the technology's functionality, reliability, usability and maintainability is an essential process to ensure that a technology product or system meets the intended requirements and performs as expected. It includes assessing whether the technology product or system performs its intended tasks and functions correctly. The goal is to verify that all the specified features and functionalities work as designed.

Research on technology acceptance, particularly on the factors that influence users' acceptance and adoption of new technologies, has been a prominent area of study. One of the most influential models in this domain is the Technology Acceptance Model (TAM) and its subsequent extensions. It gives emphasis on the level of acceptance among the possible benefactors of the

technology developed for further awareness of the devices or systems approval from the community or the sample population intended.

The study of Aurich, J., et al (2015) discusses new directions and challenges related to technology validation in the manufacturing sector. It addresses the application of validation techniques and methodologies in manufacturing processes. Through the validation process made, it addresses the lacking features that necessary for the manufacturing of the device. With this, there is really a need in every development of technology to dwell on the technology validation to look further on the safety and reliability on the developed equipment (McDermid & Kelly, 2008)

According to Minniti, R., et al (2018), organizational factors influence technology validation for product innovation. It discusses the role of different organizational structures and cultures in the validation process. Moreover, the validation process is contaminated by culture for product innovation and it is more beneficial when it is considered since the usability of the device will depend on the awareness and cultural background of the population it is intended for.

In the studies discussed were the foundation and information needed in developing the Smart Electric Grid Line Controller. Thus, the researcher of the study fathomed the need to establish validation process in the development of Smart Electric Grid Line Controller software and hardware aspect to fit the necessary features of the technology for the community that will be using the device in the future.

## II. Methodology

The researcher employed the developmental research method since this study required situational analysis, data gathering, development prototype, testing and conduct of survey that validated the functionality, efficiency, usefulness, reliability and maintainability of the device. Moreover, the realization of the system and device used the *Planning, Analysis, Design, Implementation and Sustainability* (PADIS) method.

### Planning Stage

The researcher considered the reasons why is there a need to develop the system. From the existing manual system of reconnection and disconnection, the researcher contemplates on its deficiencies and identified new needs that were raised from the interviews gathered from users and support personnel.

### Analysis Stage

From the manual system and the gathered deficiencies, the researcher gathered information from the existing literature and projects that address the same challenges. The development of Smart Electric Grid Line Controller was defined to address existing deficiencies and new needs will be specified which are broken down into specific new designs for the proposed system through



detailed planning to address hardware, interface, programming, data, and security issues through the use of literature and examining previous existing projects related to Smart Grids and Microcontrollers.

## Design Stage

These design processes include the block diagram and detailed design. Smart Electric Grid Line Controller specifications underwent two consecutive design process. The first process is the block diagram. In this process, the system as whole and was broken into components called modules. The first module illustrated the user profiling which allowed the access of information to the system – Smart Electric Grid Line Controller - in disconnection and reconnection of electric lines.

In designing stage includes the circuit design of the Smart Electric Grid Line Controller. The device consists of several key modules. First, the breadboard prototype serves as the central platform where all the hardware components are interconnected. Acting as the microcontroller, the Arduino Nano R3 module provides control and processing capabilities. The GPRS-GSM SIM900A module is responsible for receiving SMS messages from the server, enabling instructions to be sent to the microcontroller. To switch electrical circuits on or off, the relay module is utilized. Furthermore, the micro-SD module is employed to store data received when the device is connected or disconnected. LED indicators play a role in visual feedback: the green LED signifies a successful connection, the red LED indicates a disconnection, and the LED dedicated to the SD card acts as an indicator of its functionality. Together, these modules contribute to the overall functionality and monitoring of the device.

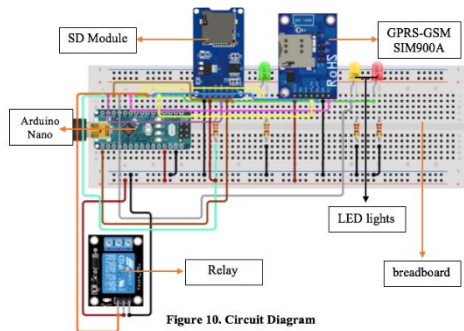
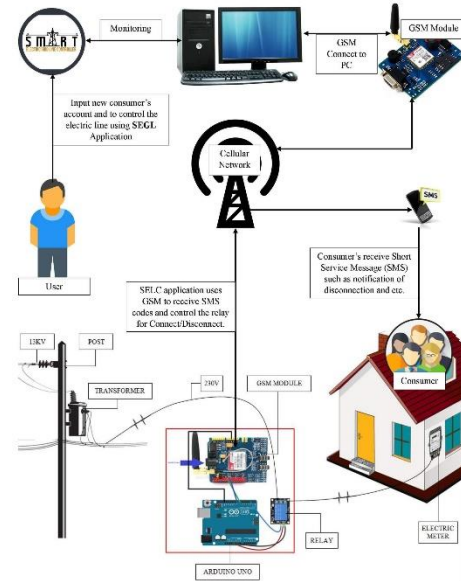

Figure 10. Circuit Diagram

## Implementation Stage

The Smart Electric Grid Line Controller was tested to the possible users, IT experts and possible consumers through the ISO standardized questionnaire (ISO 9126). The project was developed to remotely disconnect and reconnect electric lines from distant areas. It has portable application (Desktop Based/Offline) for reconnection and disconnection process, together with the Login Features for reconnection and disconnection of electric lines, consumer's profiling, generates immediate computerized history reports from the reconnection and disconnection

activities. Furthermore, it has automated monitoring for consumer's electric status and can import meter reading transactions from excel file, Device monitoring. Moreover, it can send bulk SMS Notification for consumers with notice of disconnection/reconnection and a device that will be attached in every household that is responsible for the reconnection and disconnection of electric lines. These features were tests and tried by the respondents according to its functionality, reliability, efficiency, usability and maintainability. So, as the possible consumers, the device and system were also administered according to their level of acceptance.

### **Support Stage**

The recommendations of the respondents were noted accordingly in the Implementation. Revisions and upgrades are done according to the suggestions that were quantified from the administration of prototype to the respondents.

## **III. Results and Discussion**

The Smart Electric Grid Line Controller is responsible for remote reconnection and disconnection of electric lines together with the following features included in the system. First, it includes portable desktop application for the remote reconnection and disconnection of electric lines which can be installed in the stakeholder's computer systems. Login features were also included in the system to track and monitor reconnections and disconnections of establishments together with the consumer's profile which includes the address and location of the household. Another feature included in the system is its capability to generate computerized reports on the reconnection and disconnection incidents according to when it is needed together with the need of the office to generate and export report files to excel for further usage in any department. Automated Monitoring Consumer's Electric Status is also incorporated as a feature to monitor electric line status together with the device's functionality in the area it is attached. This system can also send notice of disconnection and reconnection to multiple consumers at the same time. Moreover, it comes with the device that will be attached in every household and will be responsible of the remote disconnection and reconnection of electric lines.

This study fabricated both system and device which were tested by Twenty (N=20) software and hardware experts coming from ZAMSURECO II. The sample population assessed the system's and device's functionality, efficiency, reliability, usability and maintainability using the ISO 9126 standard questionnaire.

The system and device were found to be classified as acceptable with the overall weighted average of 3.22 for functionality, 3.34 for efficiency, 3.19 for reliability, 3.40 for usability and 3.33 for maintainability. With these results, the device and system were proved to be functional, efficient, reliable, usable and maintainable as it presumed to be modified and adapt to the current system.

Part of the device and system's validation process, technology acceptance validates the developed device and system's value proposition, drives market adoption, and fosters continuous improvement to meet user expectations. This study system and device produced were tested by thirty (N=30) random consumers of ZAMSURECO II. The sample population evaluate the products as to how it fits their acceptance for it to be used in the community through the use of ISO 9126 standard questionnaire with four (4) factors namely; Functional Suitability, Performance Efficiency, Usability and Reliability.

The Smart Electric Grid Line Controller garnered an average of 3.22 for functional Suitability, 3.32 for performance efficiency, 3.11 for usability and 3.43 for reliability. Based on the results presented, the outputs of this research were evidently acceptable for the consumer addressing their concerns with disconnection and reconnection issues.

#### IV. Conclusion

The development of this device addresses the major concern of electric shortage due to fast growing consumers with uneven consumption because of unsettled accounts every month especially those who are located in the far-flung areas. This was assessed as the source of the existing problem of fluctuation of the electricity supply in the vicinity.

Thus, the Smart Electric Grid Line Controller can automatically control electric line connection and disconnection with quality features assured by the experts including Functionality, Reliability, Usability, Efficiency Maintainability and Portability. With the features discussed, this surely address the immediate need of the possible consumer especially on the necessary immediate connection after paying their pending accounts.

#### REFERENCES

- [1] AgustínZaballos, Alex Vallejo, Marta Majoral, and Josep M. Selga, 2009. "Survey and Performance Comparison of AMR Over PLC Standards", IEEE transactions on power delivery, vol. 24, no. 2.
- [2] Ajeng S., Nandiyanti, A., Oktiani, R., Ragadhita, R., Abdullah, G. (2019), "Temperature on The Effectiveness of Arduino-Based Portable Spectrophotometer with White Light-Emitting Diode (Led) As A Light Source For Analyzing Solution Concentration", Vol. 14, No. 3 (2019) 1653 - 1661
- [3] Andie, FathulHafidh, Faruq Rahmadani (2019), "Web Based Smart Parking: IOT Microcontroller",," International Journal of Science and Research (IJSR) National Conference on Knowledge, 10.1088/1742-6596/1175/1/012056
- [4] Arvind Kumar Sainil, Garima Sharma, Kamal KishorChoure (2019), "BluBO: Bluetooth Controlled Robot," International Journal of Science and Research (IJSR) National Conference on Knowledge, Innovation in Technology and Engineering (NCKITE), 10-11 April 2015, pp. 325-328S.



- [5] Cecati, C. (2014), The Concept of Smart Grid, Research Gate, I: 10.1109/IECON.2010.5675310
- [6] David N., Chima A., Ugochukwu A., Obinna E., (2016), "Design of a Home Automation System Using Arduino", ISSN 2229-5518
- [7] Department of Energy (2018), "Philippine Power Statistics", Retrieved from: <https://www.doe.gov.ph/philippine-power-statistics>
- [8] Downets, W., (2019), "Internet of Things; New Information Chain", 2018.2.5.39 38
- [9] Ferduos, Datta, Farhana and Okana, (2019), "Modernization of Electric Metering System" 1244 (2019) 012028
- [10] Gubbi, J., Buyya, R., Marusic, S. and Palaniswami, M. (2013) "Internet of things (IoT): A Vision, Architectural Elements, and Future Directions". Future Generation Computer Systems, 29, 1645-1660.
- [11] Ibrahim, Muslimin (2015), "The Prototype Development of Creative Thinking Skills Model's Book", Research Gate, 10.1051/shsconf/20184200116
- [12] Islam Albatish, Msbah J. Mosa and Samy S. Abu-Naser, (2018), "Intelligent Tutoring System for Learning", International Journal of Academic Pedagogical Research 2 (2):1-8 (2018)
- [13] John Newbury and William Miller. (2001). "Multiprotocol Routing for Automatic Remote Meter Reading Using Power Line Carrier Systems", IEEE transactions on power delivery", vol. 16, no.1.
- [14] Keyur K Pate, Sunil M Patel (2016), Internet of Things-IOT: Definition, Characteristics, Architecture, Enabling Technologies, Application & Future Challenges
- [15] M. Moghavvemi, S.Y. Tan and S. K. Wong, (2005). "A reliable and economically feasible automatic meter reading system using power line distribution network". International Journal Of Engineering -Materials And Energy Research Center. , Vol. 18, No. 3, pp. 301-318.
- [16] Mohamed. F. Kotb, Magdi El-Saadawi, and Eman H. El-Desouky (2018), "Over Current Protection Relay using Arduino Uno for Future Renewable Electric Energy Delivery and Management (FREEDM) System", <http://dx.doi.org/10.24018/ejece.2018.2.5.39> 38
- [17] Moon Suk Choi, Ju. Seongho Ju and Yonghun Lim. (2008), "Design of Integrated Meter Reading System based on Power-Line Communication", Power Line Communications and Its Applications, 2008. ISPLC 2008. IEEE International Symposium on, pp. 280-284
- [18] Morse, (2016). "The Relativeness of Internet of Things" [doi org/10.1177/1049732316645320](http://dx.doi.org/10.1177/1049732316645320)
- [19] Mst. Jannatul, F., Tridib, D, Umme, F., and Ovi, A., (2019). "Design and Development of SMS- Based Prepaid Electricity Billing System Using GSM and Arduino," E-ISSN 2412-8856
- [20]
- [21] Nayyar and Puri, (2016), Data Glove: "Internet of Things (IoT) Based Smart Wearable Gadget", Research Gate, 10.9734/BJMCS/2016/24854
- [22] Philippine Statistics Authority (2018), "Report of Population in Mindanao", Retrieved from: <https://psa.gov.ph/content/population-region-ix-zamboanga-peninsula-based-2015-census-population-and-housing>
- [23] Smartgrid Force Task, (2015), "The Smart Grid: The Introduction", Retrieved from: [https://www.energy.gov/sites/prod/files/oeprod/DocumentsandMedia/DOE\\_SG\\_Book\\_Single\\_Pages%281%29.pdf](https://www.energy.gov/sites/prod/files/oeprod/DocumentsandMedia/DOE_SG_Book_Single_Pages%281%29.pdf)
- [24] Tanvir Ahmed, Md Suzan Miah, Md. Manirul Islam and Md. Rakib Uddin, (2014), International Journal of Engineering Science and Computing , 10.1109/CSNT.2018.8820272

- [25] Thompson, A. (2016), “Automatic Electric Meter Reading System: A Cost-Feasible Alternative Approach In Meter Reading For Bangladesh Perspective Using Low-Cost Digital Wattmeter And Wimax Technology”, Electrical Circuit Laboratory, American International University, Dhaka, Bangladesh, Retrieved from:<https://arxiv.org/pdf/1209.5431.pdf>
- [26] Tigor H.N., Muhammad A.M., Ikhsan S., Ulfi A., Esra, C., Emerson P.S., (2017), “Electrical Appliances Control Prototype by Using GSM Module And Arduino”, IEEE, 10.1109/IEA.2017.7939237
- [27] Uning Lestari, ErfantiFatkhayah, AndungFebiPrakoso, (2018), “Application Of Home Light Control System Using Arduino With Mobile Based Wifi Media”, 2598-0793
- [28] Vaniyarohit P., Kumarkhaniya Vishal S., Solanki Sanjay C., Parmarravirajsinh H. (2019). “Arduino Based Bluetooth Control Robot, Series”, 1244 (2019) 012028
- [29] Vinu V Das, (2009). “Wireless Communication System for Energy Meter Reading”, 2009 International Conference on Advances in Recent Technologies in Communication and Computing
- [30] World Population Review (2019), Population in the Philippines, Retrieved from: <http://worldpopulationreview.com/countries/philippines-population/>,
- [31] Xin Longbiao and Liu Chunlei. (2008). “Summary of Remote Meter Reading system Based On Carrier Power” Low- Voltage Apparatus. Beijing, April 2008, pp.1–4,9.
- [32] YRB Al-Mayouf, OA Mahdi, NA Taha , (2018), Efficient and stable routing algorithm based on user mobility and node density in urban vehicular network, Journal of Sensors, e0165966
- [33] YunusTjandi, SyarifuddinKasim (2019), “Electric Control Equipment Based on Arduino Relay”,0.1088/1742-6596/1244/1/012028